

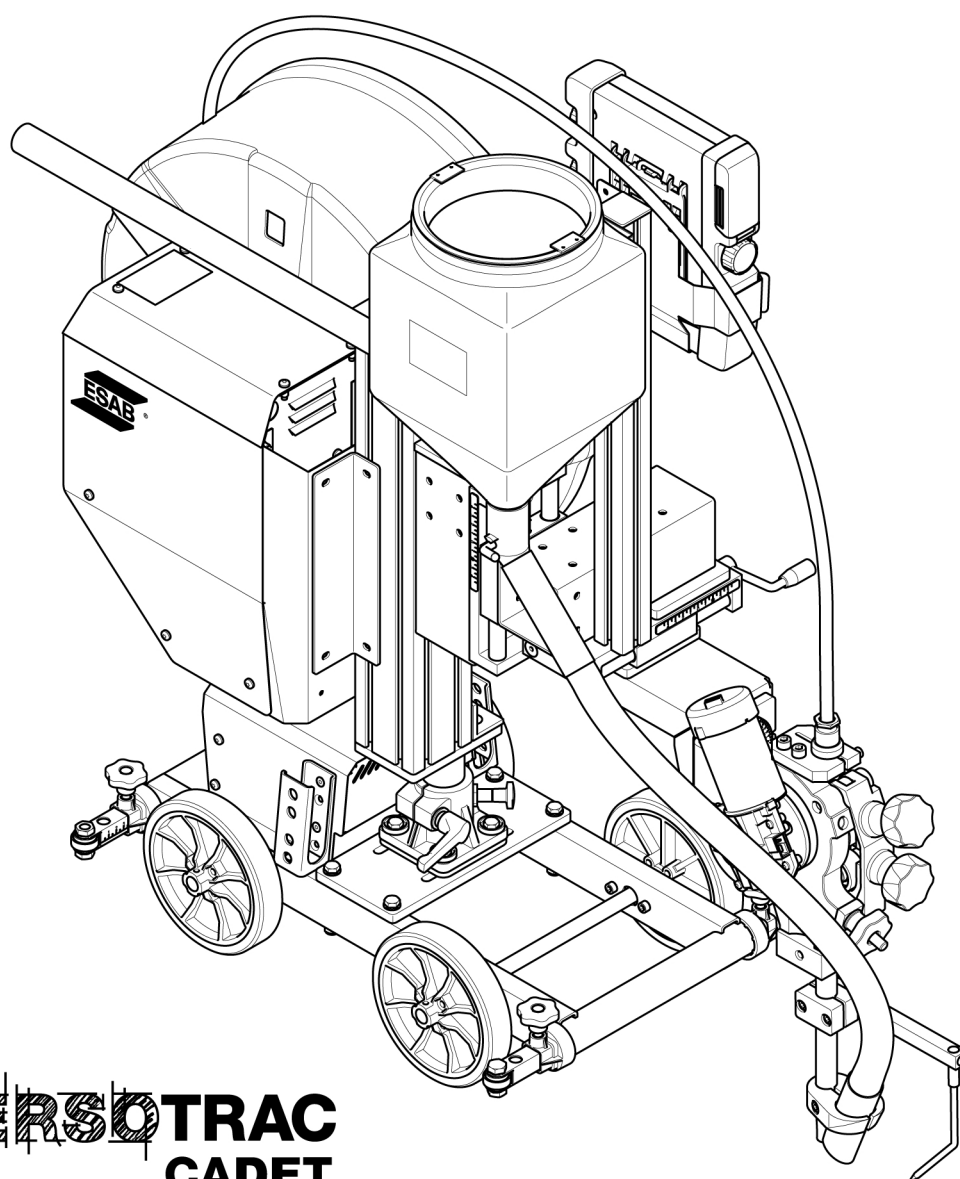

Versotrac Cadet

EWT 1000 Welding tractor



VERSOTRAC
CADET

Instruction manual
Original instructions



EU DECLARATION OF CONFORMITY

According to
The Machinery Directive 2006/42/EC, entering into force 29 December 2009
The Low Voltage Directive 2014/35/EU, entering into force 20 April 2016
The EMC Directive 2014/30/EU, entering into force 20 April 2016
The RoHS Directive 2011/65/EU, entering into force 2 January 2013

Type of equipment

Submerged arc welding tractor

Type designation

Versotrac Cadet EWT 1000

Serial number, from: xx 234 22xx xxxx,

Brand name or trademark

ESAB

Manufacturer or his authorised representative established within the EEA**Name, address, and telephone no:**

ESAB AB

Lindholmsallén 9, Box 8004, SE-402 77 Göteborg, Sweden

Phone: +46 31 50 90 00, www.esab.com

The following harmonised standard in force within the EEA has been used in the design:

EN 60974-5:2019,

Arc Welding Equipment – Part 5: Wire feeders

EN 60974-10:2014,

Arc Welding Equipment – Part 10: Electromagnetic compatibility (EMC) requirements

EN 12100:2010,

Safety of machinery – Risk assessment and risk reduction general principles for design

Additional Information:

Restrictive use, Class A equipment, intended for use in location other than residential

Flat fillet kit is optional

By signing this document, the undersigned declares as manufacturer, or the manufacturer's authorised representative established within the EEA, that the equipment in question complies with the safety requirements stated above.

Date

Signature

Position

Gothenburg

2022-08-22

Peter Kjällström

Director Welding Automation

CE 2022

1	SAFETY	5
1.1	Meaning of symbols	5
1.2	Safety precautions	5
2	INTRODUCTION	8
2.1	Welding methods	8
2.2	Horizontal welding	8
2.3	Stability	8
3	TECHNICAL DATA	9
3.1	Versotrac Cadet EWT 1000 Welding tractor	9
4	INSTALLATION	11
4.1	Lifting instruction	11
4.2	Main components	12
4.2.1	Welding cables	13
4.2.2	Bobbin holder	14
4.3	Connections	14
4.3.1	Connecting to power source	15
5	OPERATION	16
5.1	Transportation	16
5.1.1	Dismount the carriage	17
5.2	The clutch	18
5.3	Loading the welding wire	18
5.4	Changing the feed roller	19
5.5	Refilling with flux powder	19
5.6	Upgrading the tractor to 4 wheel drive	19
5.7	Control panel EAC 10	21
5.7.1	Keys and knobs	22
5.7.2	Initial configuration	23
5.7.3	Startup	23
5.7.4	Measured screen	24
5.7.5	Set screen, power source	24
5.7.6	Welding menu	25
5.8	Adjustments	26
5.9	Welding positions	26
5.10	Work piece voltage reference brush	27
5.11	Welding applications	28
5.11.1	Basic version	29
5.11.2	Idling rollers (0446 151 880)	29
5.11.3	Laser lamp (0821 440 980)	30
5.11.4	Guide wheel bogey (0413 542 880)	30
5.11.5	Grooved wheels (0443 682 881)	31
5.11.6	Flat fillet welding (0904 586 880)	31
6	MAINTENANCE	32
6.1	Daily	32
6.2	Weekly	32
7	TROUBLESHOOTING	33
7.1	Versotrac Cadet EWT 1000	33
7.2	Welding head	33

7.3	Versotrac Cadet Control unit.....	34
8	EVENT CODES	35
8.1	High DC voltage.....	35
8.2	High temperature.....	35
8.3	Low welding current.....	35
8.4	Low battery voltage.....	35
8.5	Speed error on a motor (wire feed, travel motor).....	35
8.6	Internal communication error (warning).....	35
8.7	Communication error.....	36
8.8	Lost contact with the unit.....	36
8.9	No gas flow.....	36
8.10	High welding current.....	36
8.11	Current servo saturation.....	36
8.12	High welding current.....	36
8.13	High inductance.....	36
8.14	Internal communication error (warning).....	37
8.15	Communication error.....	37
8.16	Current servo saturation.....	37
8.17	A motor has stopped.....	37
8.18	A motor has stopped.....	37
8.19	Current servo saturation.....	37
8.20	High DC voltage.....	37
8.21	High temperature.....	38
8.22	High temperature.....	38
8.23	High temperature.....	38
8.24	High inductance.....	38
8.25	Lost contact with the unit.....	38
8.26	Speed error on a motor (wire feed, travel motor).....	38
8.27	A motor has stopped.....	39
9	ORDERING SPARE PARTS	40
	WIRING DIAGRAM	41
	ORDERING NUMBERS	42
	ACCESSORIES	43
	WEAR PARTS	46

1 SAFETY

1.1 Meaning of symbols

As used throughout this manual: Means Attention! Be Alert!

**DANGER!**

Means immediate hazards which, if not avoided, will result in immediate, serious personal injury or loss of life.

**WARNING!**

Means potential hazards which could result in personal injury or loss of life.

**CAUTION!**

Means hazards which could result in minor personal injury.

**WARNING!**

Before use, read and understand the instruction manual and follow all labels, employer's safety practices and Safety Data Sheets (SDSs).



1.2 Safety precautions

Users of ESAB equipment have the ultimate responsibility for ensuring that anyone who works on or near the equipment observes all the relevant safety precautions. Safety precautions must meet the requirements that apply to this type of equipment. The following recommendations should be observed in addition to the standard regulations that apply to the workplace.

All work must be carried out by trained personnel well-acquainted with the operation of the equipment. Incorrect operation of the equipment may lead to hazardous situations which can result in injury to the operator and damage to the equipment.

1. Anyone who uses the equipment must be familiar with:
 - its operation
 - location of emergency stops
 - its function
 - relevant safety precautions
 - welding and cutting or other applicable operation of the equipment
2. The operator must ensure that:
 - no unauthorised person is stationed within the working area of the equipment when it is started up
 - no-one is unprotected when the arc is struck or work is started with the equipment
3. The workplace must:
 - be suitable for the purpose
 - be free from drafts

4. Personal safety equipment:

- Always wear recommended personal safety equipment, such as safety glasses, flame-proof clothing, safety gloves
- Do not wear loose-fitting items, such as scarves, bracelets, rings, etc., which could become trapped or cause burns

5. General precautions:

- Make sure the return cable is connected securely
- Work on high voltage equipment **may only be carried out by a qualified electrician**
- Appropriate fire extinguishing equipment must be clearly marked and close at hand
- Lubrication and maintenance must **not** be carried out on the equipment during operation



WARNING!

Arc welding and cutting can be injurious to yourself and others. Take precautions when welding and cutting.



ELECTRIC SHOCK - Can kill

- Install and ground the unit in accordance with instruction manual.
- Do not touch live electrical parts or electrodes with bare skin, wet gloves or wet clothing.
- Insulate yourself from work and ground.
- Ensure your working position is safe



ELECTRIC AND MAGNETIC FIELDS - Can be dangerous to health

- Welders having pacemakers should consult their physician before welding. EMF may interfere with some pacemakers.
- Exposure to EMF may have other health effects which are unknown.
- Welders should use the following procedures to minimize exposure to EMF:
 - Route the electrode and work cables together on the same side of your body. Secure them with tape when possible. Do not place your body between the torch and work cables. Never coil the torch or work cable around your body. Keep welding power source and cables as far away from your body as possible.
 - Connect the work cable to the workpiece as close as possible to the area being welded.



FUMES AND GASES - Can be dangerous to health

- Keep your head out of the fumes.
- Use ventilation, extraction at the arc, or both, to take fumes and gases away from your breathing zone and the general area.



ARC RAYS - Can injure eyes and burn skin

- Protect your eyes and body. Use the correct welding screen and filter lens and wear protective clothing.
- Protect bystanders with suitable screens or curtains.



NOISE - Excessive noise can damage hearing

Protect your ears. Use earmuffs or other hearing protection.

MOVING PARTS - Can cause injuries



- Keep all doors, panels and covers closed and securely in place. Have only qualified people remove covers for maintenance and troubleshooting as necessary. Reinstall panels or covers and close doors when service is finished and before starting engine.



- Stop engine before installing or connecting unit.
- Keep hands, hair, loose clothing and tools away from moving parts.

FIRE HAZARD



- Sparks (spatter) can cause fire. Make sure that there are no inflammable materials nearby.
- Do not use on closed containers.

HOT SURFACE - Parts can burn



- Do not touch parts bare handed.
- Allow cooling period before working on equipment.
- To handle hot parts, use proper tools and/or insulated welding gloves to prevent burns.

MALFUNCTION - Call for expert assistance in the event of malfunction.

PROTECT YOURSELF AND OTHERS!



CAUTION!

This product is solely intended for arc welding.



WARNING!

Do not use the power source for thawing frozen pipes.



CAUTION!

Class A equipment is not intended for use in residential locations where the electrical power is provided by the public low-voltage supply system. There may be potential difficulties in ensuring electromagnetic compatibility of class A equipment in those locations, due to conducted as well as radiated disturbances.

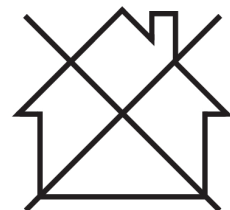

NOTE!

Dispose of electronic equipment at the recycling facility!

In observance of European Directive 2012/19/EC on Waste Electrical and Electronic Equipment and its implementation in accordance with national law, electrical and/or electronic equipment that has reached the end of its life must be disposed of at a recycling facility.

As the person responsible for the equipment, it is your responsibility to obtain information on approved collection stations.

For further information contact the nearest ESAB dealer.

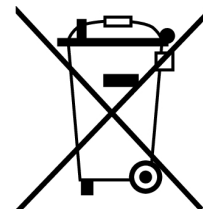

ESAB has an assortment of welding accessories and personal protection equipment for purchase. For ordering information contact your local ESAB dealer or visit us on our website.

2 INTRODUCTION

The **Versotrac Cadet EWT 1000 Welding tractor** is designed for **Submerged Arc Welding (SAW)** of butt and fillet joints.

All other applications are prohibited.

The equipment is intended for use in combination with an ESAB digital power sources **LAF xxx1**, **TAF xxx1** or **Aristo 1000**.

2.1 Welding methods

SAW

The weld bead is protected by a cover of flux during the welding.

2.2 Horizontal welding

The product described in this manual is designed for horizontal welding. The welding tractor can be used for flat fillet welding when welding a tilted fillet joint with the optional flat fillet welding kit.



NOTE!

Do not use **Versotrac Cadet EWT 1000** when welding on inclined planes.

Avoid welding on surfaces with a slope greater than 3° (>5 cm/m) due to risk of weld defects caused by the large size of the melted metal in the weld pool.

2.3 Stability



NOTE!

Always check the welding equipment for stability before welding.

The Versotrac Cadet EWT 1000 is designed to be flexible and cover many different welding applications and setups. The stability can be improved by moving the pillar holder sideways, the position of the flux container, etc.

3 TECHNICAL DATA

3.1 Versotrac Cadet EWT 1000 Welding tractor

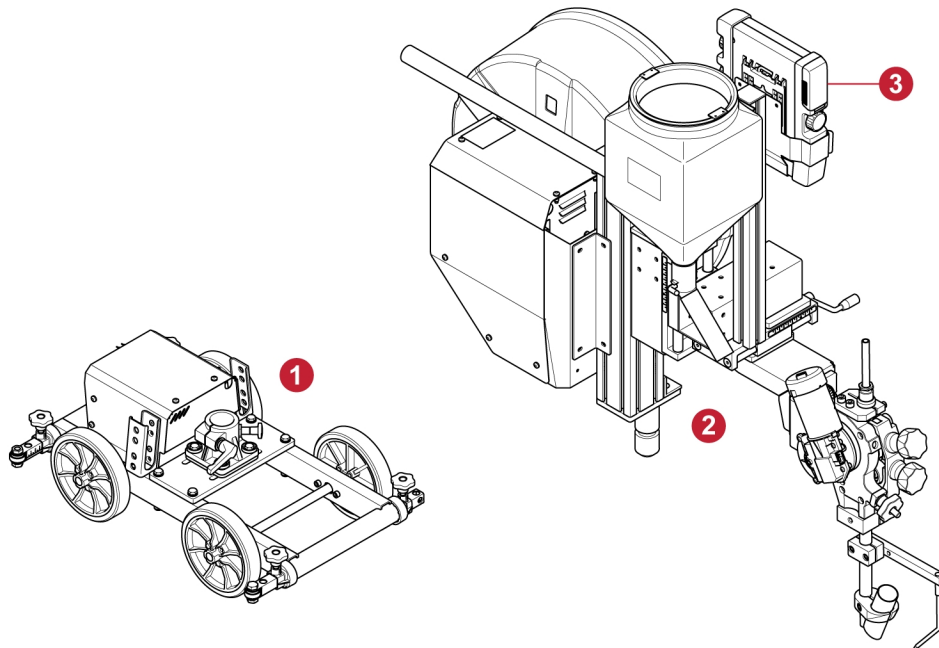

1. Tractor carriage
2. Bobbin holder, column and welding head
3. EAC 10, control pendant

Versotrac Cadet EWT 1000	
Supply voltage	60 V DC or 42 V AC, 50/60 Hz
Max power requirement	900 VA
Travel speed	0.1–2.0 m/min (0.3–6.6 feet/min)
Brake hub braking torque	1.5 Nm (13.3 in. lb)
Minimum turning radius for circumferential welding	
Inside object diameter	3000 mm (9 ft 10.11 in.)
Outside object diameter, four wheels	3900 mm (12 ft 9.54 in.)
Minimum pipe diameter for internal joint welding	1100 mm (3 ft 7.31 in.)
Maximum weight of wire	30 kg (66 lb)
Weight, excluding wire and flux	65 kg (143.3 lb)
Relative air humidity	Max 95%
Operating temperature	-10 to +40 °C (-14 to +104 °F)
Storage temperature	-20 to +55 °C (-4 to +131 °F)
Maximum surface temperature on weld object (wheel)	150 °C
EMC classification	Class A
Enclosure class	IPXX

3 TECHNICAL DATA

Welding head	
Supply voltage	42 V DC
Permissible load at 100%	1000 A
Wire dimensions	
Fe solid single	1.6–4.0 mm (0.06–0.15 in.)
SS solid	1.6–3.2 mm (0.06–0.12 in.)
Maximum wire feed speed (≤ 4 mm wire)	9.0 m/min (29.5 feet/min)
Brake hub braking torque	1.5 Nm (13.3 in. lb)
Flux hopper volume	6 l
EMC classification	Class A

4 INSTALLATION

The installation must be carried out by a professional.



WARNING!

Rotating parts can cause injury, take great care.



CAUTION!

This product is intended for industrial use. In a domestic environment this product may cause radio interference. It is the user's responsibility to take adequate precautions.

4.1 Lifting instruction



WARNING!

The welding tractor must be lifted using the lifting eye (3).

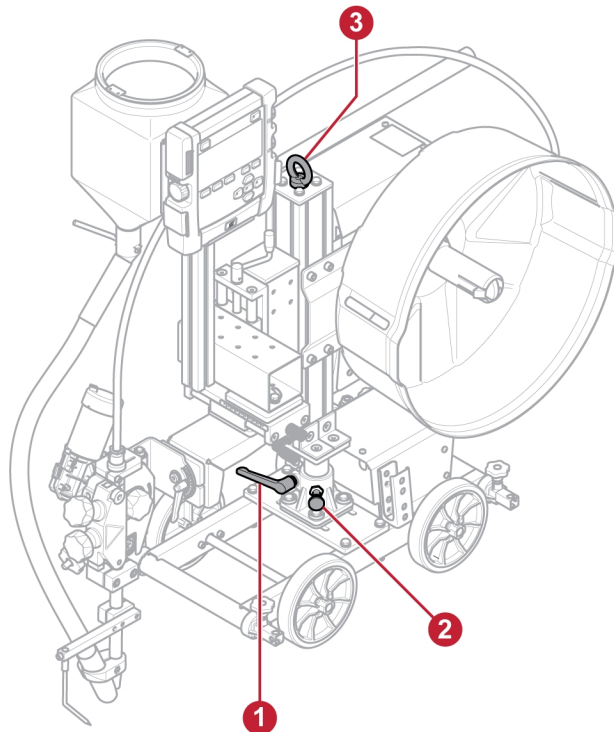

- Disconnect the power source and remove all consumables (flux and welding wire).
- Disconnect and remove welding cables from the welding tractor. The welding cables are not to be lifted with the tractor.
- Make sure the column is in locked position (1 and 2), directed forward as shown in illustration.

4.2 Main components

Versotrac Cadet EWT 1000 Welding tractor

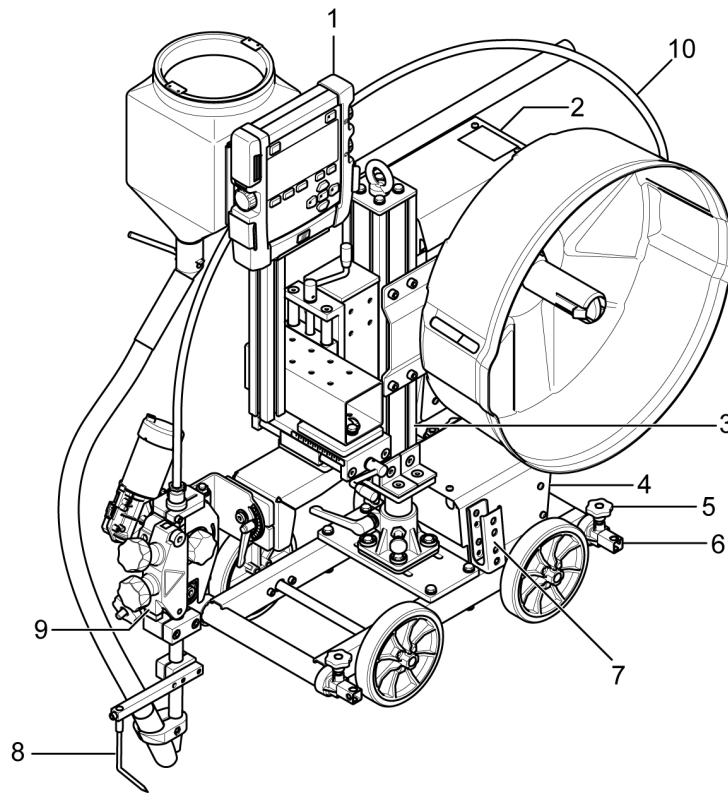

- 1. EAC 10 Control pendant
- 2. Versotrac Cadet Control unit
- 3. Column
- 4. Tractor carriage
- 5. Guide bar lock

- 6. Guide bar
- 7. Cable support
- 8. Guide pin
- 9. Welding head
- 10. Wire liner

Welding head

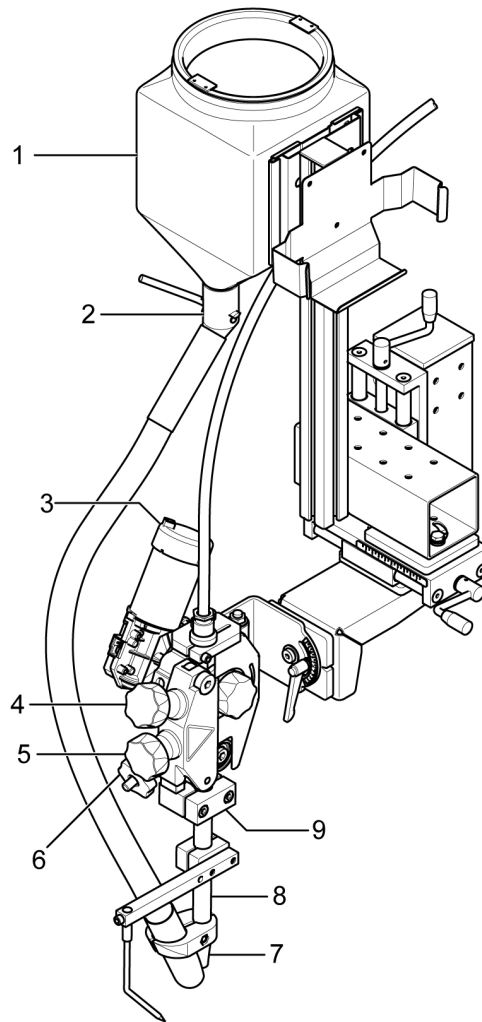

- | | |
|----------------------------|--------------------------------------|
| 1. Flux hopper | 6. Wire straightener memory function |
| 2. Flux valve | 7. Contact tip |
| 3. Wire feed motor | 8. Contact tube |
| 4. Wire feed pressure roll | 9. Welding current connection |
| 5. Wire straightener | |

4.2.1 Welding cables

Use different number of welding cables for different welding currents:

- | | |
|--------------|--------------------------------|
| Up to 500 A | one 120 mm ² cable |
| 500 - 1000 A | two 120 mm ² cables |



NOTE!

With two welding cable setup, run the welding cables close to each other in parallel, but do not twist them around each other.

4.2.2 Bobbin holder

Mount the wire drum on the brake hub in the bobbin holder.

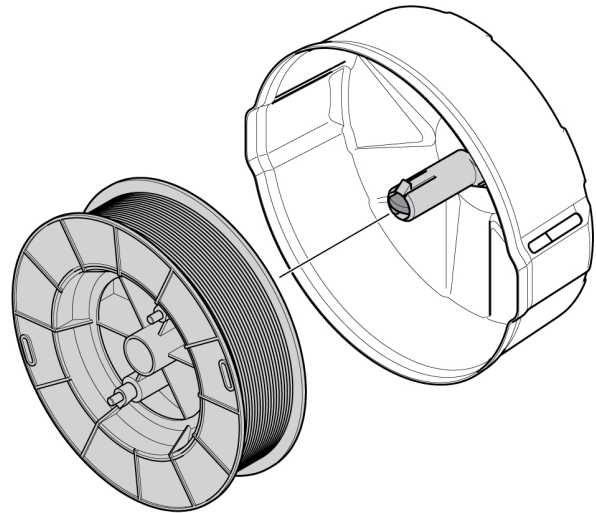

4.3 Connections

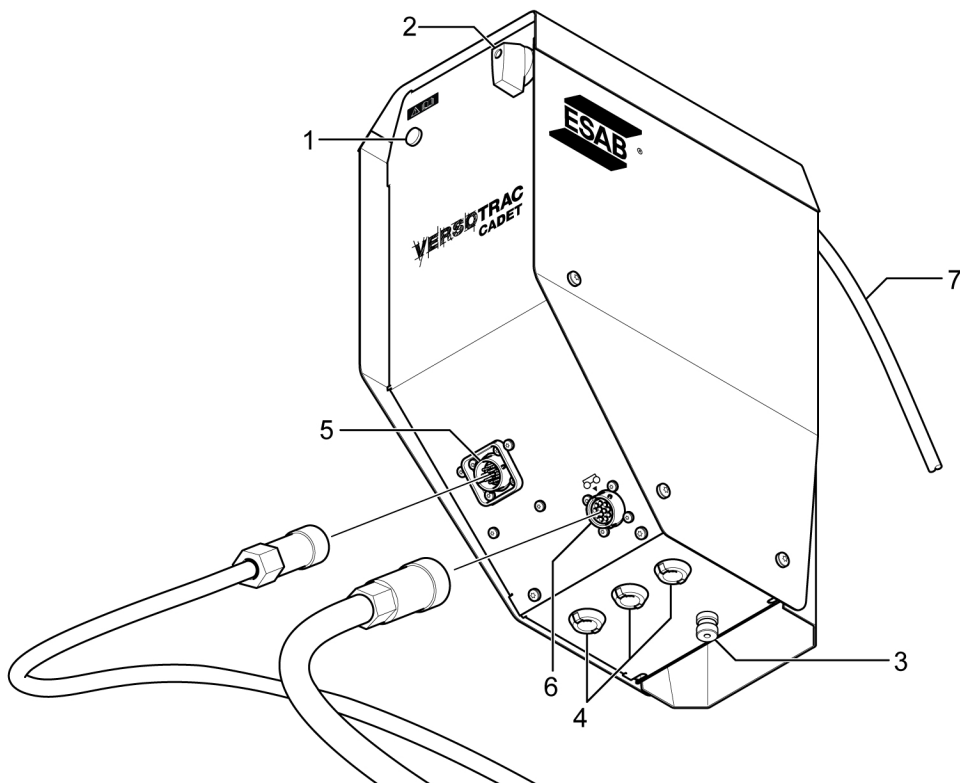

- | | |
|--|--------------------------------|
| 1. On/Off indicator | 5. Connection power source |
| 2. On/Off switch | 6. Connection tractor carriage |
| 3. Connection work piece voltage reference brush | 7. Cable to control pendant |
| 4. Accessory cable entries | |

4.3.1 Connecting to power source

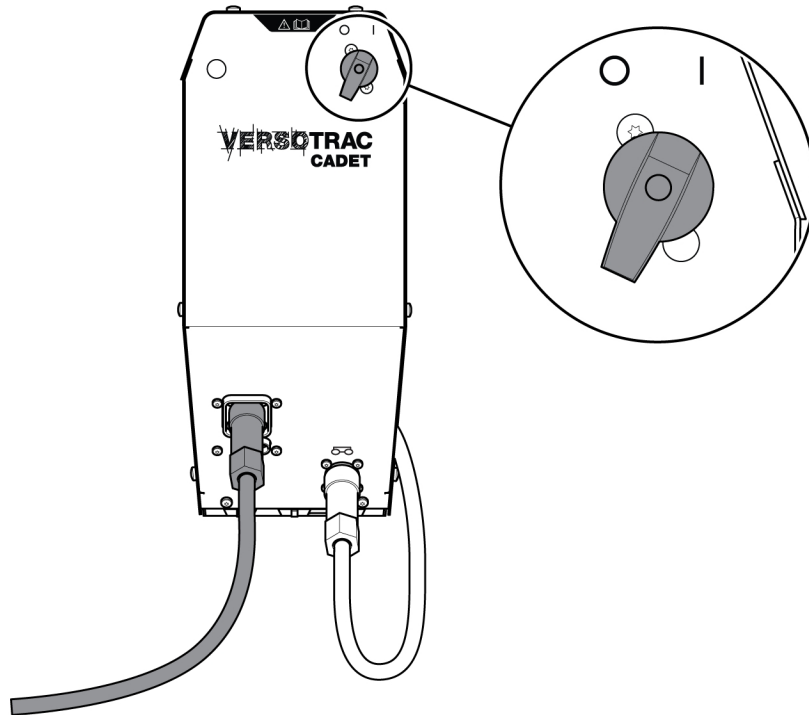

Connect the interconnection cable to connector.

Interconnection cable between CAN based ESAB power source and Verotrac Cadet Control unit are available as accessories in different lengths.

ESAB CAN based power sources are LAF xxx1, TAF xxx1 and Aristo® 1000.

For further information about connecting welding power source, see separate instruction manual.

Always use the dust cover on the connection where no cable is connected.

5 OPERATION

**CAUTION!**

Read and understand the instruction manual before installing or operating.



General safety regulations for handling the equipment can be found in the "SAFETY" chapter of this manual. Read it through before you start using the equipment!

**NOTE!**

When moving the equipment use intended handle. Never pull the cables.

**NOTE!**

The tractor is supplied with a strap. It can be used to collect the welding cables behind the tractor.

5.1 Transportation

It is possible to transport the **Versotrac Cadet EWT 1000 Welding tractor** by following the instructions in section "Lifting instructions".

**NOTE!**

Make sure the welding head has cooled down before transportation.

- 1) Turn off and disconnect the power source. Disconnect the cables to the welding head and the tractor carriage (1). Remove the cables from the welding tractor.

**NOTE!**

If the power source is disconnected without turning off power first, the power source emergency stop can be activated.

- 2) Remove wire from wire feed unit and wire liner (2).

3) Remove the wire bobbin.

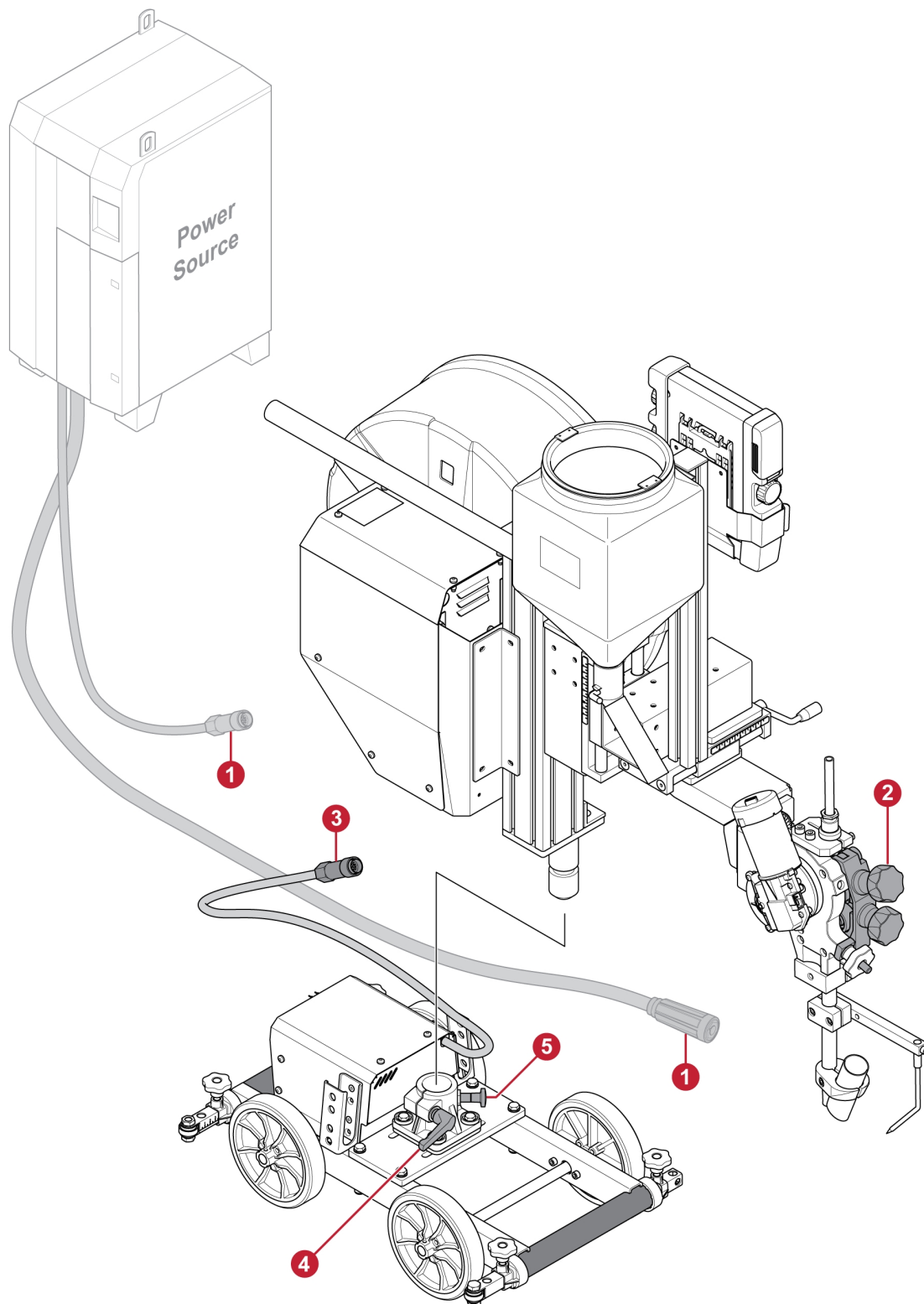

5.1.1 Dismount the carriage

- 1) Make sure the column is positioned in the middle of the tractor carriage.
- 2) Disconnect the cable (3) between the tractor carriage and the control unit

- 3) Unlock the column rotation with the handle (4). Rotate to end point. Pull (5) and rotate a few more degrees.

5.2 The clutch

Use the clutch knob in the back of the tractor carriage to lock and unlock the wheels from the motor. The wheels will be engaged with the motor when in locked position.

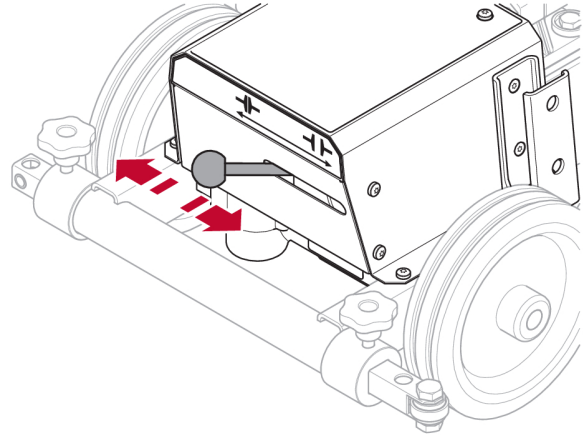

5.3 Loading the welding wire



NOTE!

The feed rollers are marked with their respective groove diameter (D) on the side of the roller.

1. Turn off the Versotrac Cadet Control unit using the On/Off switch.
2. Check that feed roller (1) and contact nozzle (2) have the correct dimension for the selected welding wire.
3. Turn the knob (3) to release the wire straightener.
4. Lift up the wire straightener with memory (4). There will be no change in the settings.
5. Feed the welding wire (5) into the contact nozzle.
6. Lower the wire straightener with memory (4) back to its position. Lock by turning the knob (3) fully.
7. Turn on the Versotrac Cadet Control unit and select the welding wire when prompted on the display.
8. With EAC 10 control panel: Feed the welding wire through the contact nozzle until it is visible below the contact nozzle.
9. When needed, adjust wire feed pressure with knob (6).
10. When needed, adjust wire straightness with knob (7).

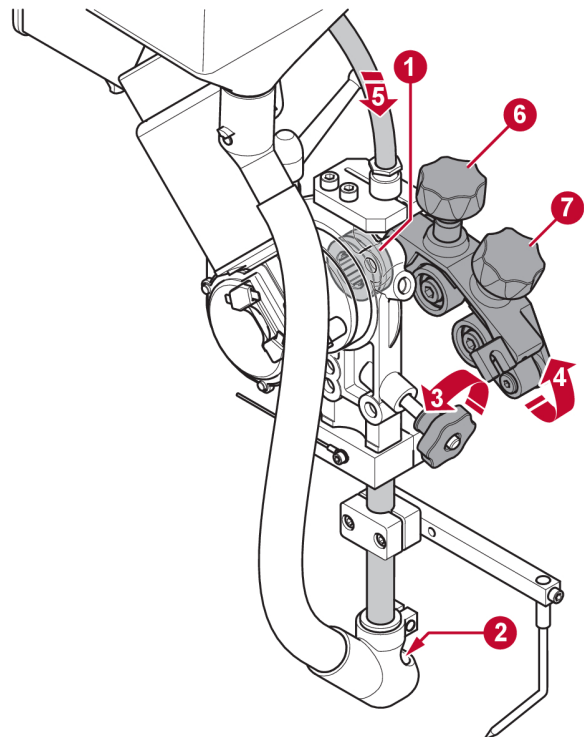

NOTE!

Do not tighten feed pressure knob (6) too hard. This can result in overheating the wire feeder.

5.4 Changing the feed roller

1. Release the knob (3).
2. Release the hand wheel (2).
3. Change the feed roller (1).

The feed rollers are marked with their respective wire sizes.

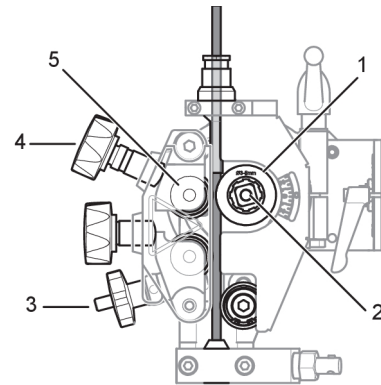

5.5 Refilling with flux powder

1. Close the flux valve (1) on the flux hopper.
2. Remove the optional cyclone on the flux recovery unit, if fitted.
3. Fill with flux powder.



NOTE!

The flux powder must be dry. Use preheated flux powder only when the flux hopper is designed for that.

4. Position the flux tube without twisting it.
5. Adjust the height of the flux nozzle above the weld so that the correct amount of flux is delivered.

Flux coverage should be sufficient so that penetration of the arc does not occur.

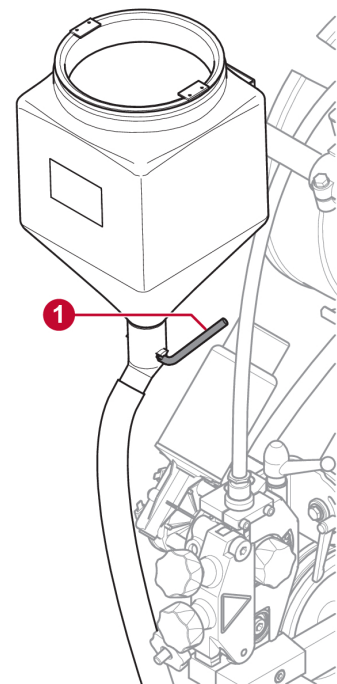

5.6 Upgrading the tractor to 4 wheel drive



NOTE!

The following pictures can differ from the Cadet version of the tractor. The pictures are however correct when it comes to handling the equipment.

5 OPERATION

1. Dismount the welding tractor according to the instructions in chapter "Dismount the carriage".
2. Remove the cable support and wheels held by the roll pins on one side.

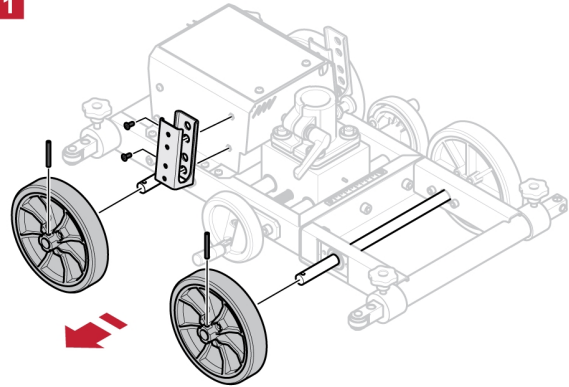

3. Mount the sprockets to the wheels using the included screws.

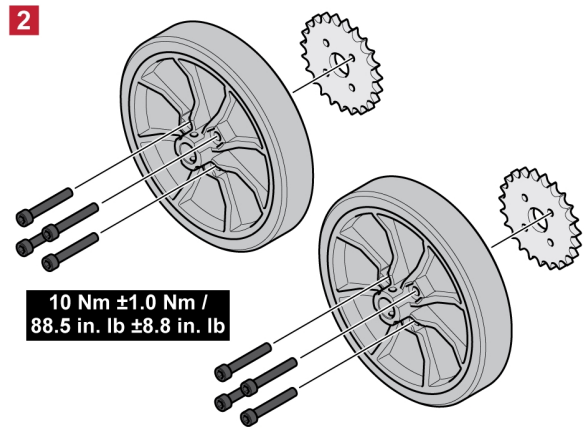

4. Mount the wheels onto the shafts and lock them in position using the roll pins.

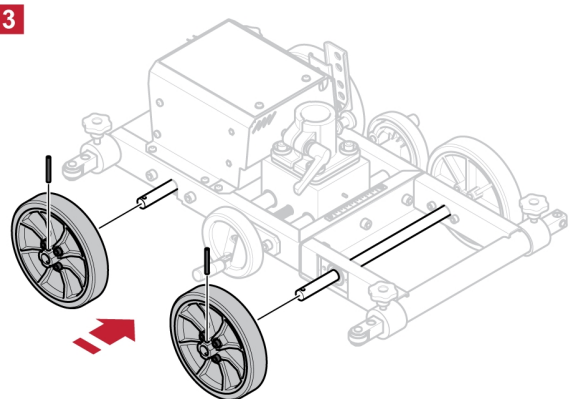

5 OPERATION

- Put the chain onto the sprockets and lock with chain lock.

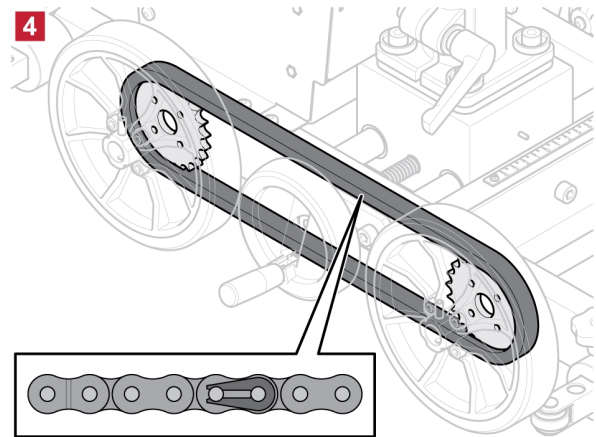

- Mount the chain protection and the cable support using the included bolts.

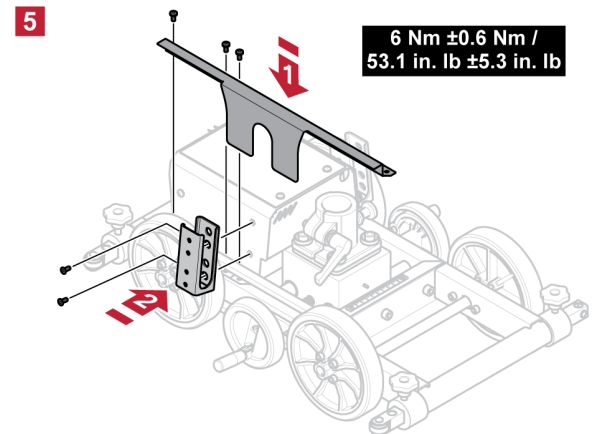

5.7 Control panel EAC 10

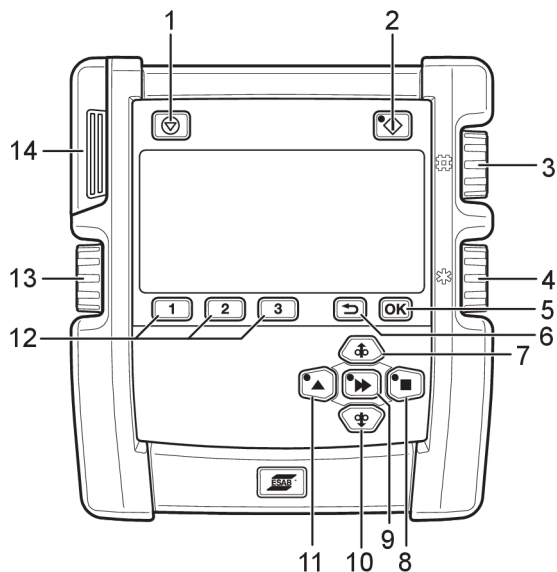

- | | |
|---|------------------------------------|
| 1. Welding stop | 8. Manual travel motion direction |
| 2. Welding start | 9. Fast motion |
| 3. Welding current / Wire feed speed/balance* | 10. Manual wire feed downwards |
| 4. Arc voltage / Offset voltage* | 11. Manual travel motion direction |
| 5. OK / Setting menu | 12. Memory 1, 2, 3 / Soft keys |
| 6. Back | 13. Travel speed / frequency* |
| 7. Manual wire feed upwards | 14. USB connection |

*Only with Aristo® 1000 in AC mode.

5.7.1 Keys and knobs

The buttons are used for Up, Down, Right, Left and Confirm (middle button) during configuration and setting.

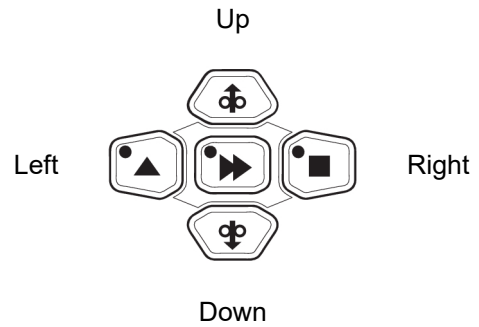

Welding stop (1). Stops all travel motions, all motors and welding current.



Welding start (2). The LED is lit when welding is in progress.



The **OK** button (5) is used to confirm a selected choice.



The **Back** button (6) is used to go back one step into the menu.



Press **Manual wire feed upwards** button (7) to feed the wire upwards. The wire is fed as long as the button is pressed.



Press **Travel motion** (8) button to drive in the direction of welding where the symbol is indicated on the weld equipment.



Fast motion button (9) is used together with other buttons to increase speed. Press the button to activate fast motion and then press manual wire feed (7, 10) or travel motion (8, 11) button. The LED on the fast motion button is lit while fast motion is activated. Press again to deactivate fast motion.

During configuration, it is possible to confirm and save a value and return to previous screen using the Fast motion button.



Press **Manual wire feed downwards** button (10) to feed the wire downwards. The wire is fed as long as the button is pressed.



Press **Travel motion** (11) button to drive in the direction of welding where the symbol is indicated on the weld equipment.



Three different welding data memories per welding head can be stored in the control panel memory using the soft keys 1, 2 and 3 (12). The soft keys have also varying functions depending on which menu currently is in use. The current function can be seen from the text in the bottom row of the display.

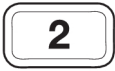

The welding current / wire feed speed/balance knob¹ (3) is used for increasing or decreasing set values.



The arc voltage / offset voltage knob¹ (4) is used for increasing or decreasing set values.



The travel speed/frequency knob¹ (13) is used for increasing or decreasing set values.

¹ Only with Aristo® 1000 in AC mode.

5.7.2 Initial configuration

At first startup after delivery, after a program update and after a completed reset, the control panel requires initial configuration. The initial configuration starts automatically.

Initial configuration can also be initiated by pressing and holding *OK* during startup, while the ESAB logo is shown.

It is possible for an authorised user to change the configuration in the *GENERAL SETTINGS* menu.

- 1) Select language using the Up/Down/Right/Left buttons. Confirm with *OK* or with the middle button.
- 2) Select measurement unit using the Right/Left buttons. Confirm with *OK* or with the middle button.
- 3) Set date using the Up/Down buttons. Change between year, month and day with the Right/Left buttons. Confirm with *OK* or with the middle button.
- 4) Set time using the Up/Down buttons. Change between hours and minutes with the Right/Left buttons. Confirm with *OK* or with the middle button.
- 5) Select wire type using the Up/Down buttons. Confirm with *OK* or with the middle button.
- 6) Select wire dimension using the Up/Down buttons. Confirm with *OK* or with the middle button.
- 7) After initial configuration, the control panel continues to the *SET* menu.

5.7.3 Startup



- 1) The software version is shown on the control panel during startup.
- 2) Previously selected wire type and wire dimension is shown. Press any button within 7 seconds to open the menu. Select wire type and wire dimension using the buttons Up/Down and *OK*.
If no button is pressed, the control panel continues to the *SET* menu with no changes on wire type or wire dimension.

5.7.4 Measured screen

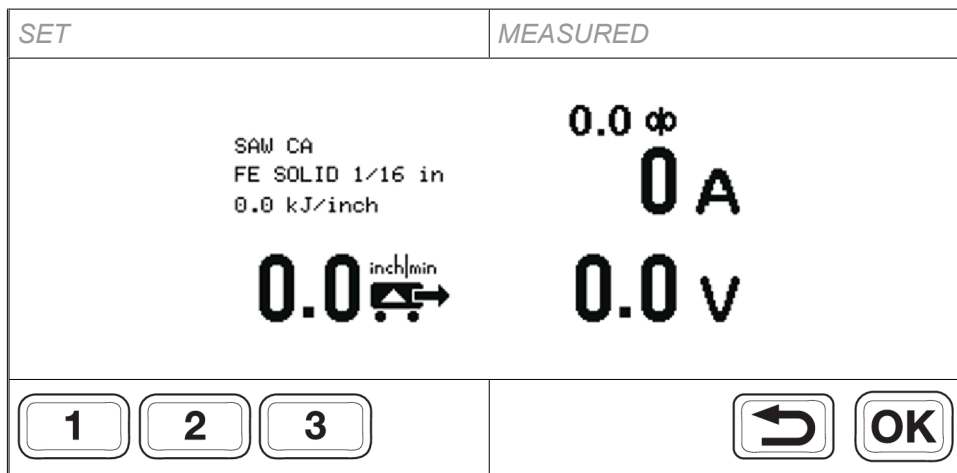

The **MEASURED** screen shows the measured values during welding. The information on the screen depends on the selected welding method.

The screen shows information divided into four parts:

Method, wire, heat input	Amperage
Travel speed	Voltage

OK A short press on **OK** when an AC power source is connected will open the AC settings screen. A long press on **OK** opens the **WELDING MENU** settings screen.

Turn any of the knobs after welding stop to open the **SET** screen. The values are shown and the **SET** screen is kept open.

1 A short press on any of the keys 1, 2, or 3 recalls the corresponding memory slot. The **SET** screen is opened and the values are displayed.

5.7.5 Set screen, power source

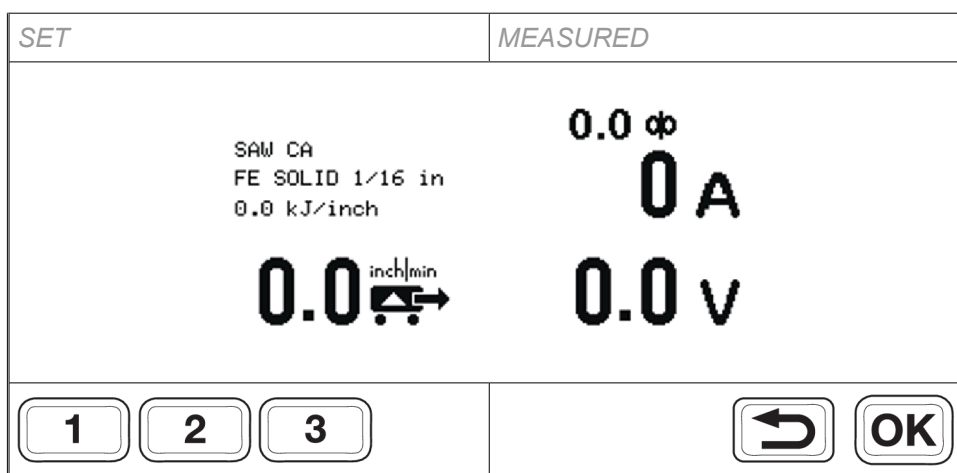

The *SET* screen is used to change welding settings and save settings to the memory slots using the keys 1, 2 and 3.

Turn any of the knobs during welding to open the *SET* screen from the *MEASURED* screen. The values are shown during 2 seconds before returning to the *MEASURED* screen unless any adjustments are made.

If the *SET* screen is opened without ongoing welding, it will stay active. When welding starts, the *MEASURED* screen is activated.

Change the welding settings by using the knob next to the value shown on the display. It is possible to save the settings for easy access.

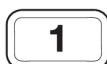

A short press on any of the keys 1, 2 or 3 will display the saved welding data memory settings, set the values and show the *MEASURED* screen again. The welding data memory number in use is shown on the *SET* tab and also with a bar above the key with the corresponding number.



With AC power source: A short press on the OK button opens the *AC SETTINGS* screen.





A long press on the OK button opens the *WELDING MENU*. Return by pressing the Back button.



5.7.6 Welding menu



When any of the screens *SET* or *MEASURED* is shown, press long on OK to open the extended *WELDING MENU*.

The information on the display depends on the authorisation level, attached power source and welding head. The authorisation level is shown with an icon in the upper right corner of the display.

Example of welding menu for Aristo® 1000 AC/DC			
	<i>WELDING MENU</i>		
	<i>METHOD</i>	<i>DC+</i>	
	<i>REGULATION TYPE</i>	<i>CA</i>	
	<i>START TYPE</i>	<i>DIRECT</i>	
	<i>CRATER FILL TIME</i>	<i>0.0 s</i>	
	<i>BURNBACK TIME</i>	<i>0.50 s</i>	

Example of welding menu for SAW welding with LAF or TAF			
	<i>WELDING MENU</i>		
	<i>REGULATION TYPE</i>	<i>CA</i>	
	<i>START TYPE</i>	<i>DIRECT</i>	
	<i>CRATER FILL TIME</i>	<i>0.0 s</i>	
	<i>BURNBACK TIME</i>	<i>0.7 s</i>	



Select the *WELDING MENU* by pressing the Right button.



Select a menu row using the Up/Down buttons and press OK or confirm with the middle button.



Set a numerical value using the Arc voltage / Offset voltage knob (4). Other values are selected using the Up and Down buttons.



Press OK or the Middle button to confirm and return to the previous menu level. The new value is displayed.



Return to previous menu level **WITHOUT** changed settings with Back or the Left button.



5.8 Adjustments

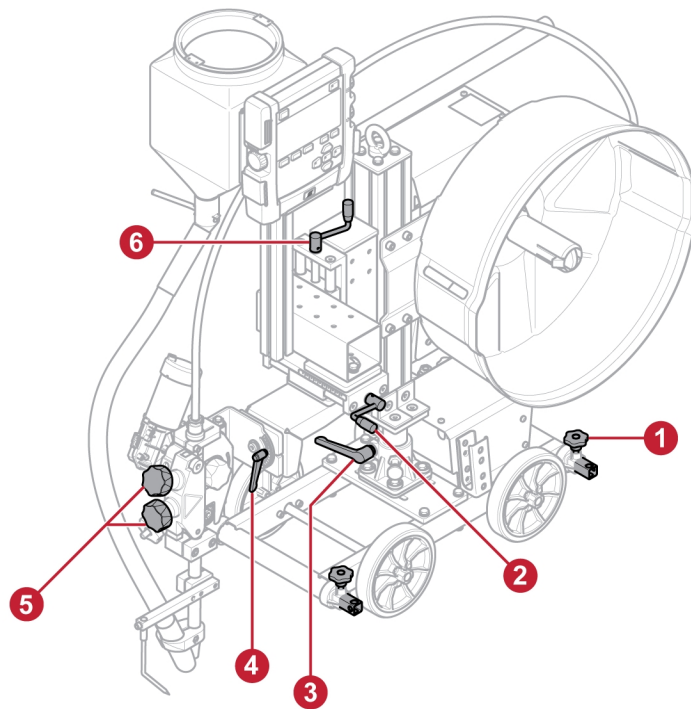

- 1) Adjust the guide roller device distance, both in front and back of welding tractor.
- 2) Adjust the horizontal/cross seam slide, see scale next to the slide.
- 3) Adjust the rotation angle of the column.
- 4) Adjust the rotation angle of the welding head, see scale next to handle.
- 5) Adjust the wire pressure.
- 6) Vertical adjustment of the welding head, see scale next to the slide.

5.9 Welding positions

It is possible to adjust and change the angles of the weld head and other parts such as flux container and pendant. Below there are tips on how to adjust the weld head angle.

Some things are important to make sure, to get the benefits of this tractor:

- The horizontal slide is meant to be cross seam at all times, so the weld head can be adjusted easily before and during welding.
- The wire liner is located in a good position that makes the wire go in to the wire straightener in the correct angle.

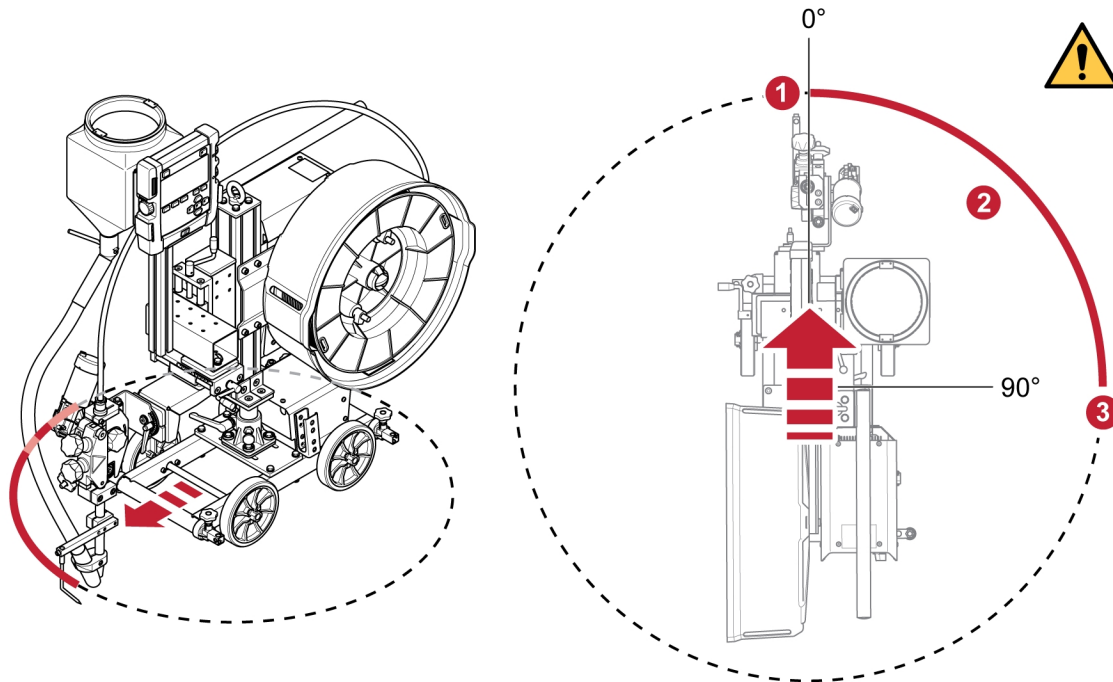

- 1) Welding head position in front of the tractor: Welding head is in the middle position as it is delivered.
- 2) Welding head position between 0 and 90°: Use the two adjustments on the top and underneath the horizontal slide to put the weld head between 0-90°. Make sure that the horizontal slide is cross seam and the wire liner is placed in a good position.
- 3) Welding head position on the side of the tractor: By turning the top adjustment on the horizontal slide 90° and turn the adjustment underneath the horizontal slide 90°, the horizontal slide cross seam and the wire liner will be in a good position, with the right angle in to the wire straightener.

5.10 Work piece voltage reference brush

The Versotrac offers an alternative work piece voltage reference through a mounted brush. The work piece voltage reference brush provides a stable work piece voltage reference for the welding power source. The solution effectively eliminates disturbance in the arc voltage measuring cables by providing a more stable welding arc.

This is the recommended solution for work piece reference when welding with an AC power source with Versotrac.

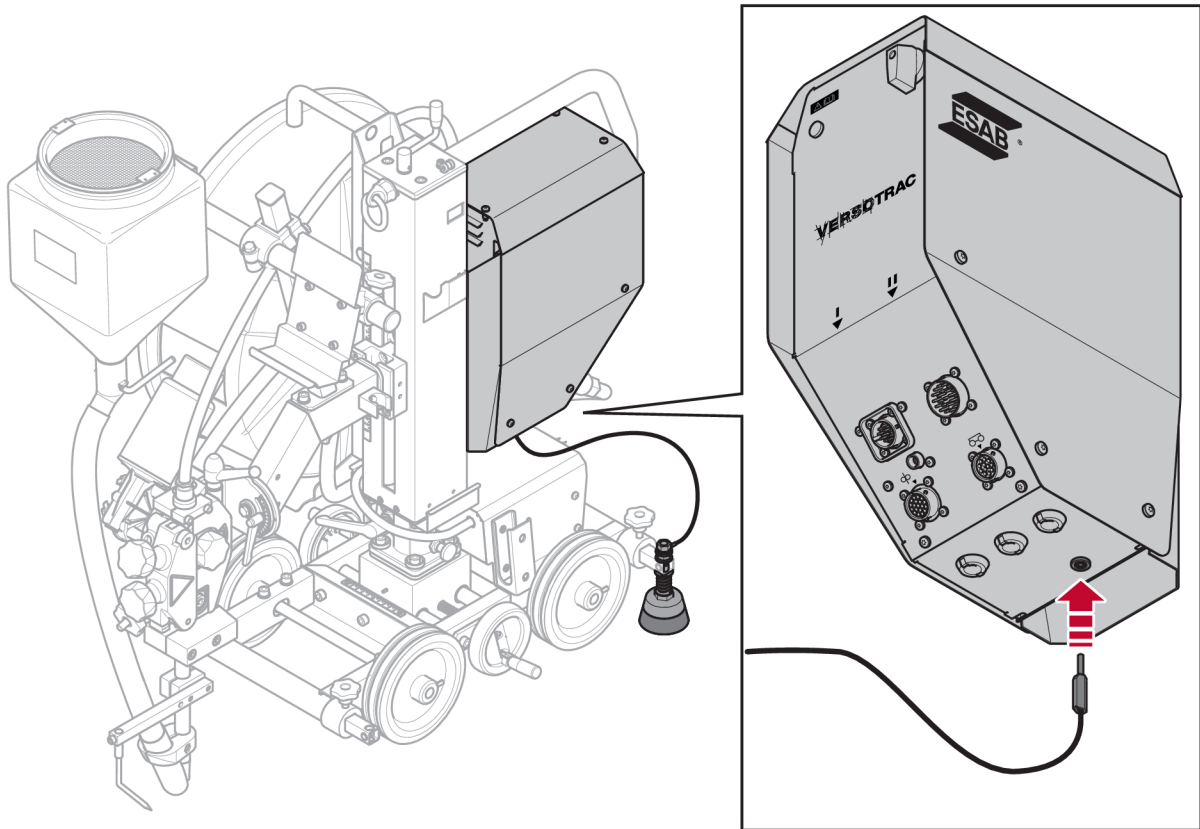

Mount the work piece voltage reference brush on any of the guide bars.

Connect the cable into the work piece voltage reference input on the control unit.



NOTE!

Control cable 0446 146 880-885 is required between the control unit and the power source. See chapter "ACCESSORIES".

5.11 Welding applications



NOTE!

The following pictures can differ from the Cadet version of the tractor. The pictures are however correct when it comes to handling the equipment.

5.11.1 Basic version

Versotrac Cadet EWT 1000 in basic version with guide roller device. This positions the welding tractor correctly along fillet welds with the driving wheels angled about $0.5-1^\circ$ in towards the vertical plate and with guide roller device steering along a guide parallel to the joint. The guide may be part of the workpiece or a separate guide rail that has been aligned parallel to the joint. Circular fillet welding. The welding tractor follows the joint using the basic guide arm device. Minimum radius 3.9 m.

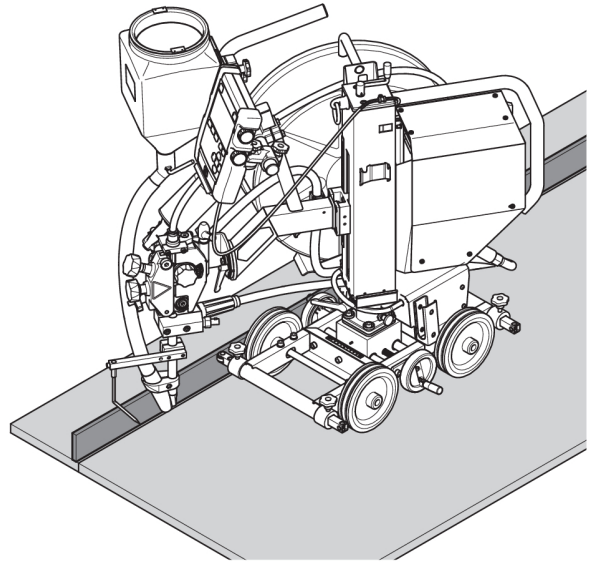

5.11.2 Idling rollers (0446 151 880)

Idling rollers with adjustable height are supplied as an accessory. Two idling rollers are required when fillet welding along a low vertical plate. The idling rollers can also be used for various types of workpieces, for example along guide edges parallel to the weld joint. See chapter "ACCESSORIES".

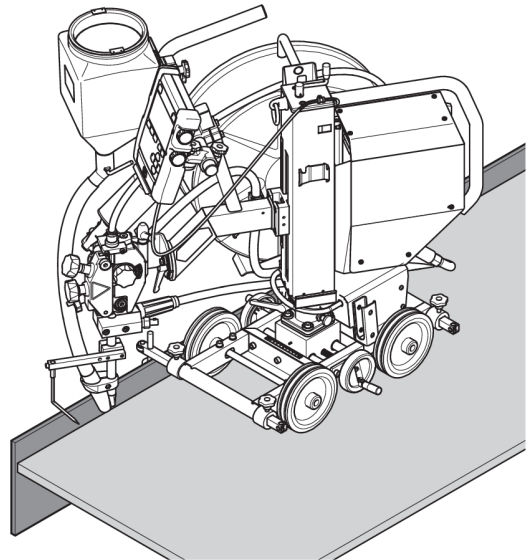

5.11.3 Laser lamp (0821 440 980)

If there is no suitable edge along which to steer the welding tractor mechanically, for example when making an I-joint, the laser lamp will be helpful with submerged-arc welding in order to indicate the position of the welding nozzle in the joint.

See chapter "ACCESSORIES".

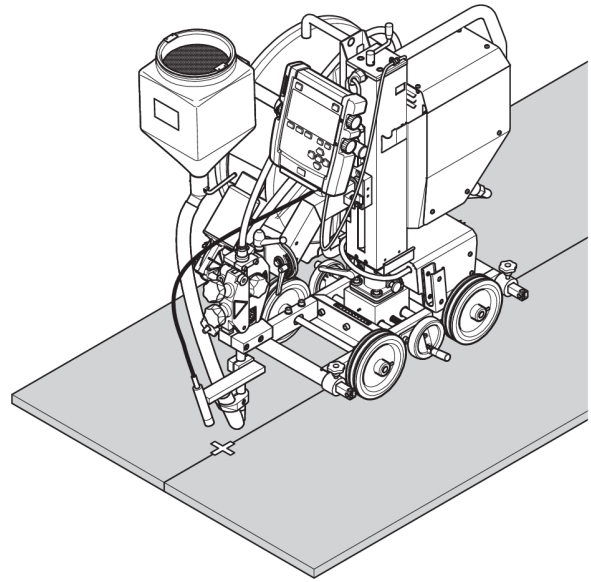

5.11.4 Guide wheel bogey (0413 542 880)

Use of the guide wheel bogey in a V-joint allows the welding tractor to track the joint. The welding tractor can pass over tack welds without problems, and without losing the track. The guide wheel bogey is secured to the contact tube, and the welding nozzle is positioned to weld behind the guide wheel bogey.

See chapter "ACCESSORIES".

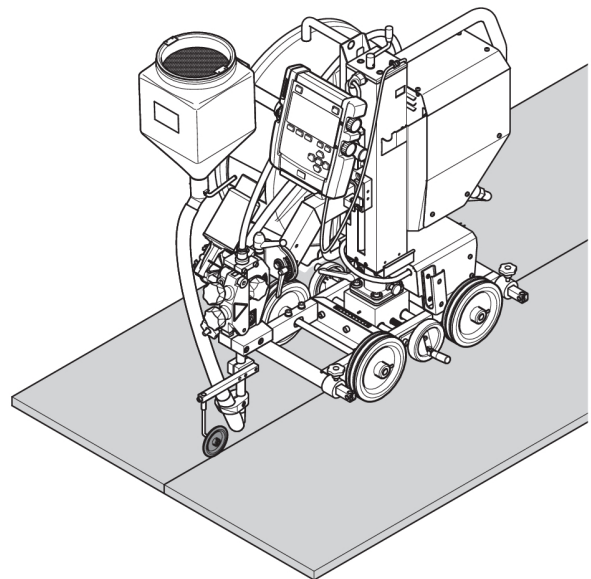

5.11.5 Grooved wheels (0443 682 881)

If there is no suitable edge along which to steer the welding tractor, as when making an I-joint, it can be fitted with two grooved wheels, which will run on an angle iron guide rails can be joined together to make up the required length. See chapter "ACCESSORIES".

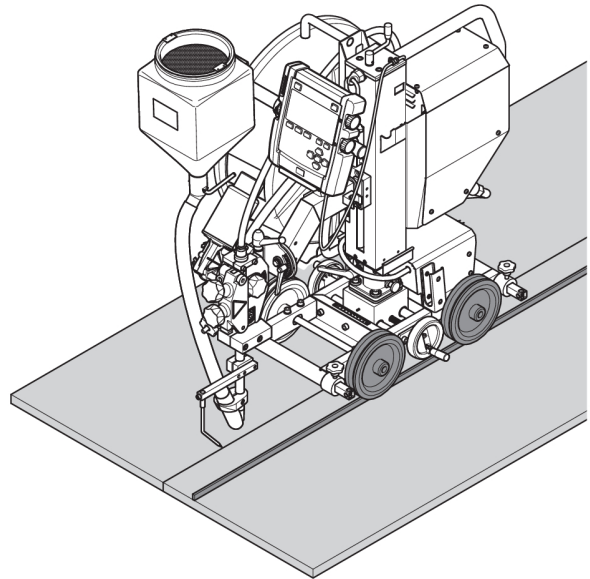

5.11.6 Flat fillet welding (0904 586 880)

The flat fillet welding kit can be used to keep the equipment straight upwards when welding a tilted fillet joint.

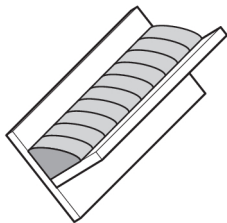

The angle can be set to 0, 30° and 45°. See chapter "ACCESSORIES".

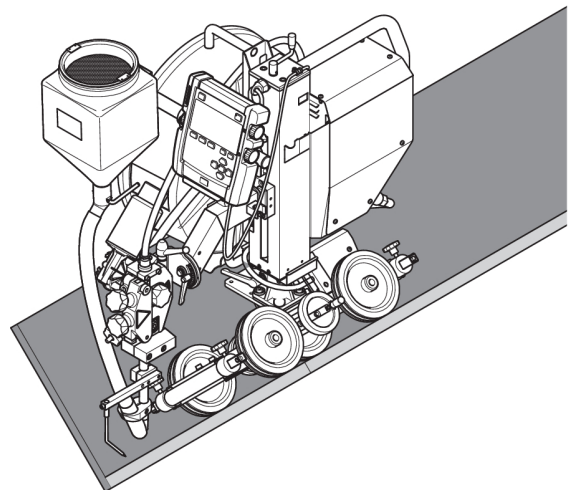

6 MAINTENANCE



CAUTION!

All warranty undertakings from the supplier cease to apply if the customer attempts any work to rectify any faults in the product during the warranty period.



NOTE!

Before doing any kind of maintenance work, make sure the mains cable is disconnected.

For maintenance of the **Versotrac Cadet Control unit**, see separate instruction manual.

6.1 Daily

- Clean flux and dirt off moving parts.
- Clean flux and dirt off slides.
- Check:
 - The rotation lock between the carriage and the column.
- Check that the contact tip and all electrical cables are connected.
- Make sure all screwed joints are tightened.
- Check that guides and drive rollers are not worn or damaged.
- Check the brake hub braking torque. Tighten if the wire reel continues to rotate when the wire feed is stopped. Loosen if the feed rollers slip. As a guide, the braking torque for a 30 kg wire reel should be 1.5 Nm.
To adjust the braking torque, see section "Adjusting the brake hub".

6.2 Weekly

- Inspect the slides. Lubricate them, if they are binding.

7 TROUBLESHOOTING

Perform these checks and inspections before sending for an authorised service technician.

7.1 Versotrac Cadet EWT 1000

Type of fault	Possible cause	Action
No travel motion	Poor electrical connection.	Clean and tighten all electrical connections.
		Check cables.
Incorrect motor speed	Error in encoder. No feedback in the system.	Clean and tighten all electrical connections.
		Check cables.

7.2 Welding head

Type of fault	Possible cause	Action
Current and voltage readings show large fluctuations	Contact jaws or nozzle are worn or wrong size.	Replace contact jaws or nozzle.
	Wire feed roller pressure is inadequate.	Increase pressure on wire feed rollers.
Wire feed is uneven	Pressure on wire feed rollers is incorrectly set.	Adjust pressure on wire feed rollers.
	Wire feed rollers are of the wrong size.	Replace wire feed rollers.
	Grooves in wire feed rollers are worn.	Replace wire feed rollers.
Wire feed is not functioning	Wire feed roller pressure is inadequate.	Adjust pressure on wire feed rollers.
	Wrong feed roller is used.	Replace feed roller.
Welding cables are overheating	Poor electrical connection.	Clean and tighten all electrical connections.
	Cross-sectional area of welding cables is too small.	Use cables with a larger cross-section or use parallel cables.
Incorrect motor speed	Error in encoder. No feedback in the system.	Check the electrical connections.
		Check cables.
Bad or no start of welding or arc ignition	Poor electrical connection in welding cables.	Tighten the screws attaching the welding cables.
		Check welding cables.
	Poor connection for welding wire.	Make sure that the welding wire is straightly cut.
Poor welding result	Aristo 1000: Poor connection for welding wire, no (+) feedback.	Check the electrical connections. Check cables.
	Bad or no feedback to the system.	Check the electrical connections. Check cables.
	LAF, TAF: No (-) feedback.	Check the electrical connections. Check cables.

7.3 Versotrac Cadet Control unit

Type of fault	Possible cause	Action
Control unit does not start, diode not lit	42 V missing.	Check the electrical connections.
		Check control cable.
		Check if On/Off switch is in the right position.
Control pendant does not start	12 V missing.	Check the electrical connections.
		Check cable.

8 EVENT CODES

Error management codes are used to indicate that an error has occurred in the welding process. It is indicated in the display via a pop-up menu.

This manual describes the error codes for **Versotrac Cadet EWT 1000**. The error codes for other units are described in the manuals for these units.

For Error codes of the Versotrac Cadet Control unit, see separate instruction manual.

4 High DC voltage

1. Check if the main voltage is too low or too high.

6 High temperature

The power source has overheated. Welding is cancelled. Welding is permitted again when the temperature falls below the maximum temperature parameter.

1. Check that the cooling air inlets or outlets are not obstructed or clogged with dirt.
2. Check the duty cycle being used, to make sure that the equipment is not being overloaded.

7 Low welding current

The weld arc has been shut down due to too low welding current during the welding process.

1. Is reset at next weld start. If the error persists, send for a service technician.

8 Low battery voltage

Battery voltage too low. If the battery is not replaced, all stored data will be lost. This error does not disable any functions.

1. Send for a service technician to replace the battery.

11 Speed error on a motor (wire feed, travel motor)

A motor cannot maintain its speed. Welding stops.

1. Check that the wire feed has not jammed or runs too fast. If the error persists, send for a service technician.
2. If the error persists, send for a service technician.

12 Internal communication error (warning)

The load on the system's CAN-bus is temporarily too high. The power source may have lost contact with the control unit

1. Check that all the equipment is correctly connected. If the error persists, send for a service technician.

14 Communication error

The system's CAN bus has temporarily ceased to work due to excessive load.

The current welding process is stopped.

1. Check the equipment to ensure that only one wire feed unit or remote control unit is connected.
2. If the error is repeated, send for a service technician.

17 Lost contact with the unit

Lost contact with a unit.

1. Check wiring and the connector between the control unit and power source.

32 No gas flow

Start prevented.

1. Check the gas valve, hoses and connectors.

43 High welding current

Power source have switched off the welding process because the current has exceeded the maximum current parameter for the power source.

1. Is reset at next weld start. If the error persists, send for a service technician.

44 Current servo saturation

The welding process has stopped because it has not advanced within 10 seconds.

1. Is reset at next weld start. If the error persists, send for a service technician.

71 High welding current

Power source have switched off the welding process because the current has exceeded the maximum current parameter for the power source.

1. Is reset at next weld start. If the error persists, send for a service technician.

88 High inductance

Inductance is too high, depending on long welding cables and/or high weld data.

1. Adjust the welding data.

93 Internal communication error (warning)

The load on the system's CAN-bus is temporarily too high. The power source may have lost contact with the control unit

1. Check that all the equipment is correctly connected. If the error persists, send for a service technician.

95 Communication error

The system's CAN bus has temporarily ceased to work due to excessive load.

The current welding process is stopped.

1. Check the equipment to ensure that only one wire feed unit or remote control unit is connected.
2. If the error is repeated, send for a service technician.

100 Current servo saturation

The welding process has stopped because it has not advanced within 10 seconds.

1. Is reset at next weld start. If the error persists, send for a service technician.

168 A motor has stopped

There are no pulses from the motor pulse transducer.

For LAF and TAF: 168 = Motor M1 (Wire feeder motor), 169 = Motor M2 (Travel motor).

1. Check the motor cables. Replace the pulse transducer.

169 A motor has stopped

There are no pulses from the motor pulse transducer.

For LAF and TAF: 168 = Motor M1 (Wire feeder motor), 169 = Motor M2 (Travel motor).

1. Check the motor cables. Replace the pulse transducer.

2310 Current servo saturation

The power source has temporarily delivered maximum current.

1. If the error persists, try lowering the weld data.

3205 High DC voltage

1. Check if the main voltage is too low or too high.

4201 **High temperature**

The power source has overheated. Welding is cancelled. Welding is permitted again when the temperature falls below the maximum temperature parameter.

1. Check that the cooling air inlets or outlets are not obstructed or clogged with dirt.
2. Check the duty cycle being used, to make sure that the equipment is not being overloaded.

4202 **High temperature**

The power source has overheated. Welding is cancelled. Welding is permitted again when the temperature falls below the maximum temperature parameter.

1. Check that the cooling air inlets or outlets are not obstructed or clogged with dirt.
2. Check the duty cycle being used, to make sure that the equipment is not being overloaded.

4203 **High temperature**

The power source has overheated. Welding is cancelled. Welding is permitted again when the temperature falls below the maximum temperature parameter.

1. Check that the cooling air inlets or outlets are not obstructed or clogged with dirt.
2. Check the duty cycle being used, to make sure that the equipment is not being overloaded.

5010 **High inductance**

Inductance is too high, depending on long welding cables and/or high weld data.

1. Adjust the welding data.

8117 **Lost contact with the unit**

Lost contact with a unit.

1. Check wiring and the connector between the control unit and power source.

8411
sub-code
0 **Speed error on a motor (wire feed, travel motor)**

A motor cannot maintain its speed. Welding stops.

1. Check that the wire feed has not jammed or runs too fast. If the error persists, send for a service technician.
2. If the error persists, send for a service technician.

8411
sub-code
1

A motor has stopped

There are no pulses from the motor pulse transducer.

For LAF and TAF: 168 = Motor M1 (Wire feeder motor), 169 = Motor M2 (Travel motor).

1. Check the motor cables. Replace the pulse transducer.

9 ORDERING SPARE PARTS



CAUTION!

Repair and electrical work should be performed by an authorised ESAB service technician.
Use only ESAB original spare and wear parts.

The Versotrac Cadet EWT 1000 is designed and tested in accordance with international and European standards **IEC/EN 60974-5**, **IEC/EN 60974-10** and **EN 12100:2010**. On completion of service or repair work, it is the responsibility of the person(s) performing the work to ensure that the product still complies with the requirements of the above standard.

Spare parts and wear parts can be ordered through your nearest ESAB dealer, see [esab.com](https://www.esab.com). When ordering, please state product type, serial number, designation and spare part number in accordance with the spare parts list. This facilitates dispatch and ensures correct delivery.

APPENDIX

WIRING DIAGRAM

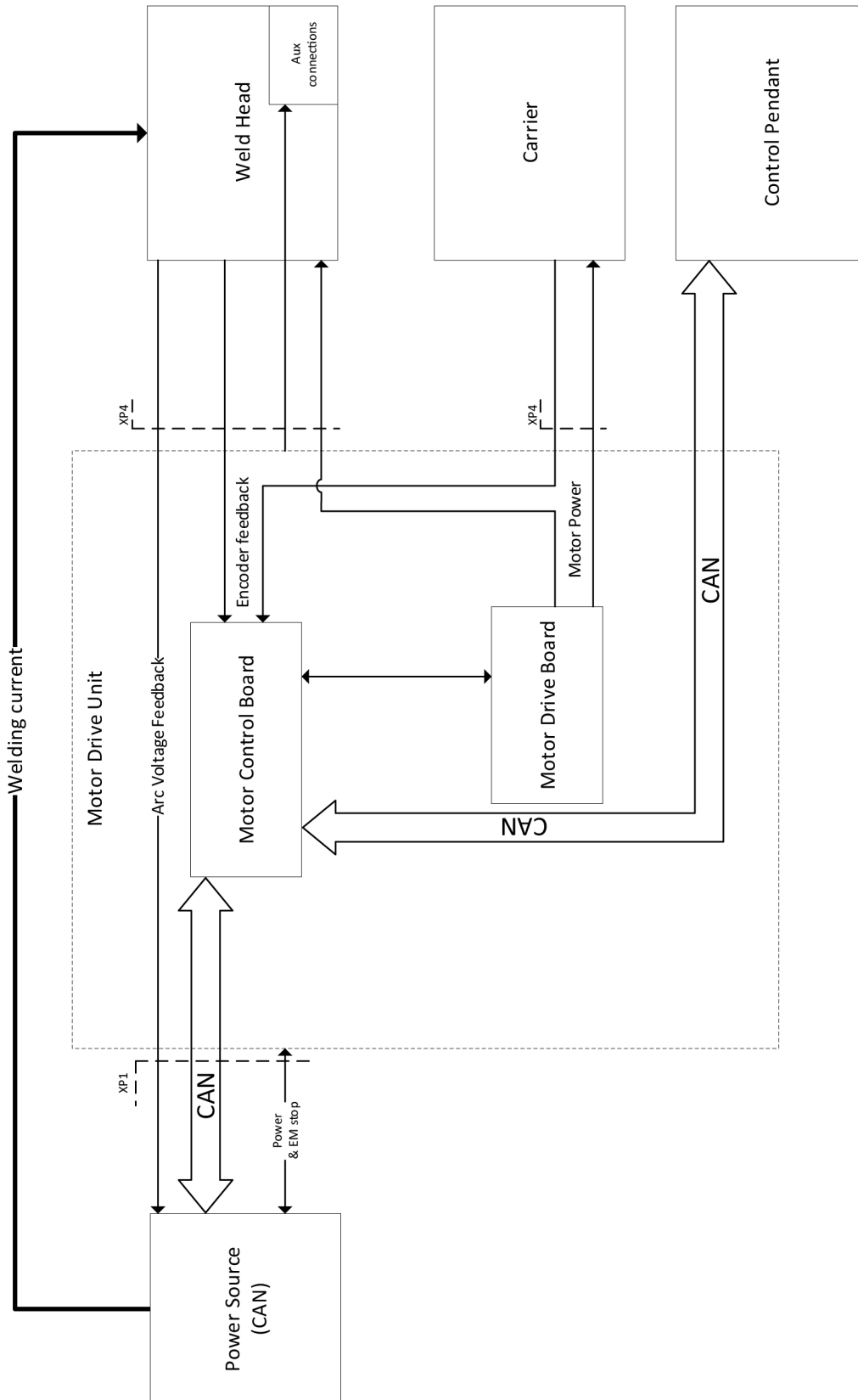

ORDERING NUMBERS

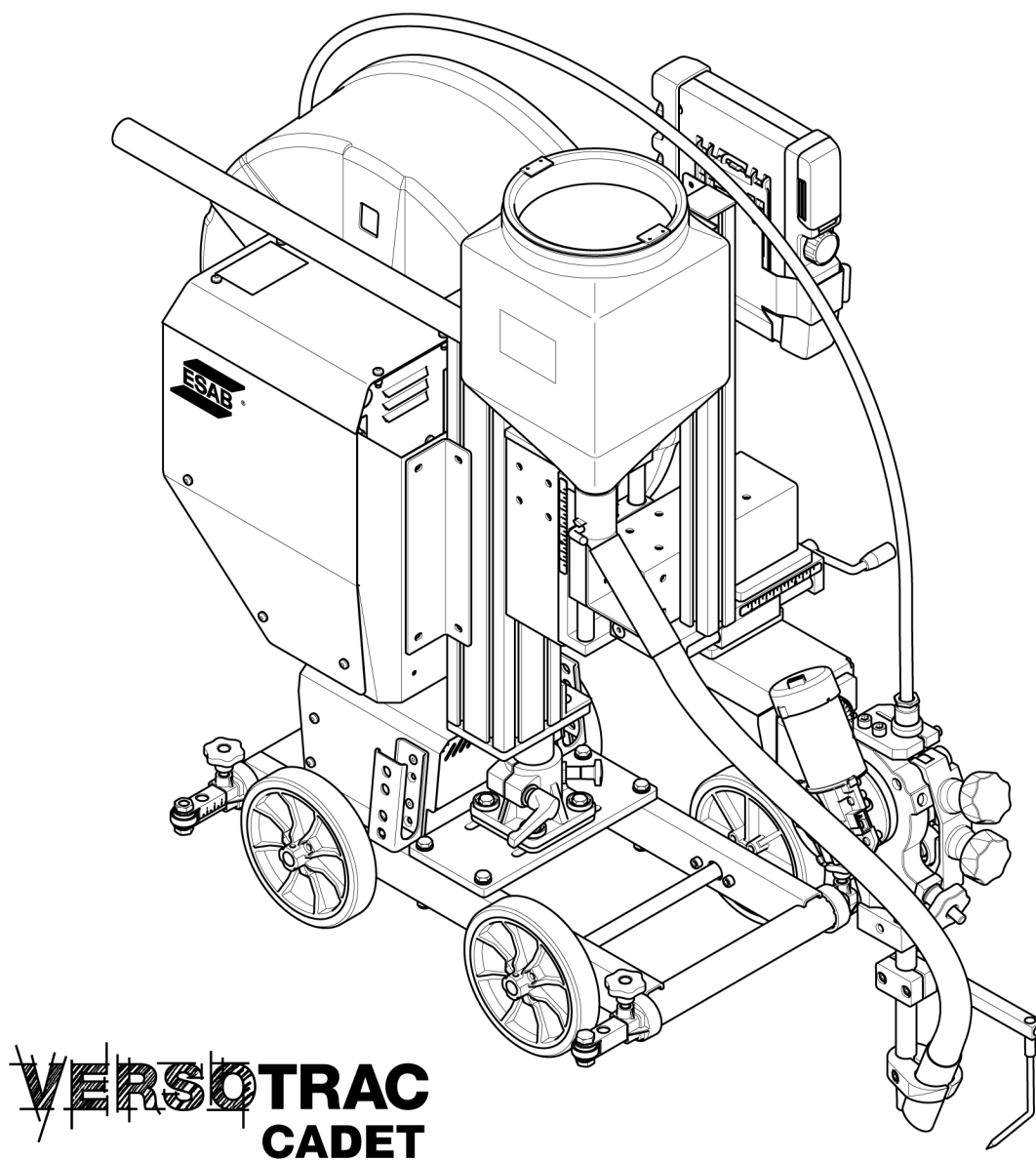



VERSOTRAC CADET

Ordering number	Denomination	Type	Notes
0910 944 880	Welding tractor	Versotrac Cadet EWT 1000	
0910 944 881	Welding tractor	Versotrac Cadet EWT 1000 4WD	
0463 877 *	Instruction manual	Versotrac Cadet Control unit	
0463 612 *	Instruction manual	EAC 10 control panel	Describes software functions.
0463 894 001	Spare parts list		

The three last digits in the document number of the manual show the version of the manual. Therefore they are replaced with * here. Make sure to use a manual with a serial number or software version that corresponds with the product, see the front page of the manual.

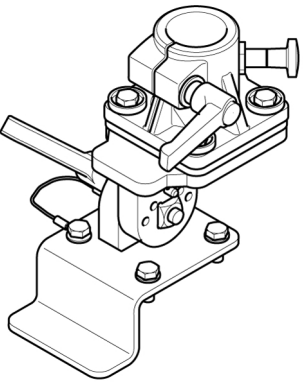
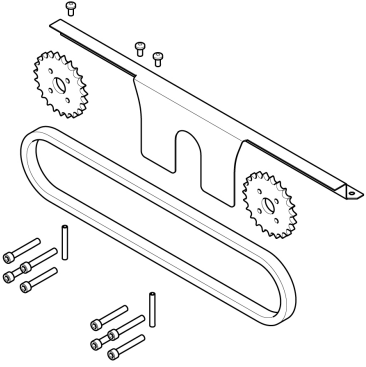
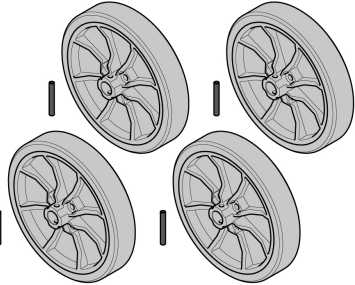
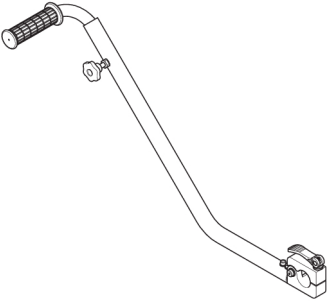

Technical documentation is available on the Internet at: www.esab.com

ACCESSORIES

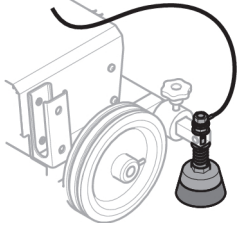
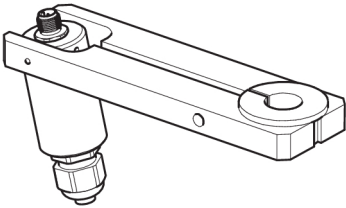
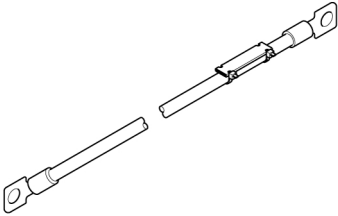
Versotrac Cadet EWT 1000		
0904 586 880	Flat fillet welding kit	 A detailed line drawing of a flat fillet welding kit, showing a complex assembly of metal components including a base plate, a vertical support, and various adjustment knobs and levers.
0910 053 880	4 wheel drive kit	 A line drawing of a 4 wheel drive kit, featuring a long metal frame with two gears mounted on top, and several bolts and nuts scattered below it.
0910 531 880	Wheel kit	 A line drawing of a wheel kit, showing four wheels arranged in a 2x2 grid. Each wheel has a multi-spoke design and a central hub.
0904 537 880	Steering handle	 A line drawing of a steering handle, consisting of a long, curved metal arm with a textured grip at one end and a mounting bracket at the other.
0446 151 880	Idling roller (1 piece)	 A line drawing of an idling roller, which is a long, thin cylindrical rod with a wider, flanged base at one end.

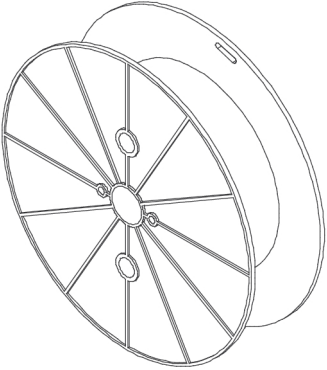
Versotrac Cadet EWT 1000		
0443 682 881	V-wheeltrack steel (4 pcs)	
0443 682 880	V-wheeltrack steel (1 piece)	
0332 947 880	Bracket suction	
0904 223 880	Work piece voltage reference brush	
0413 542 880	Guide wheel bogey. For V-joints, used for joint tracking, for fitting on the contact tube.	
0154 203 880	Guide rail with magnets, 3 m (9.8 ft). Several lengths of guide rail can be used.	
Welding head		
0821 440 980	Laser lamp kit, 2 m (6 ft 6.7 in.) cable	
Welding cable with cable lug		
0413 768 899	95 mm ² , 15 m (49 ft)	
0413 768 882	95 mm ² , 24 m (78 ft)	
0413 768 885	95 mm ² , 34 m (111 ft)	
0413 768 911	95 mm ² , 50 m (164 ft)	
0413 768 912	95 mm ² , 75 m (246 ft)	
0413 768 896	120 mm ² , 15 m (49 ft)	
0413 768 889	120 mm ² , 24 m (78 ft)	
0413 768 892	120 mm ² , 34 m (111 ft)	
0413 768 907	120 mm ² , 50 m (164 ft)	
0413 768 913	120 mm ² , 75 m (246 ft)	
0810 093 880	Flexible arm	
0148 140 880	Flux recovery unit OPC	
0413 315 881	Flux hopper of silumin alloy	
0145 221 881	Concentric flux feeding funnel	

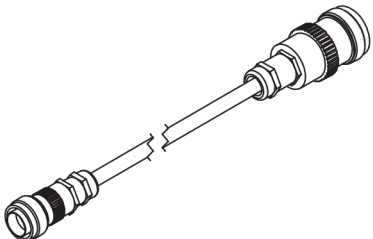
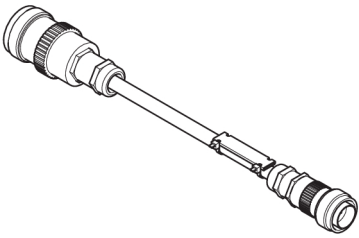
Contact tube		
0413 510 001	260 mm (10.24 in.)	
0413 510 002	190 mm (7.48 in.)	
0413 510 003	100 mm (3.94 in.)	
0413 510 004	500 mm (1 ft 7.7 in.)	
0413 511 001	Contact tube, bent	
0153 872 880	Wire reel, plastic, 30 kg	

Versotrac Cadet Control unit		
Control cable Versotrac Cadet Control unit - digital power source		
0460 910 880	5 m (16 ft)	
0460 910 881	15 m (49 ft)	
0460 910 882	25 m (82 ft)	
0460 910 883	35 m (115 ft)	
0460 910 884	50 m (164 ft)	
0460 910 885	75 m (246 ft)	
0460 910 886	100 m (328 ft)	
Control cable Versotrac Cadet Control unit - digital power source and work piece voltage reference brush		
0446 146 880	5 m (16 ft)	
0446 146 881	15 m (49 ft)	
0446 146 882	25 m (82 ft)	
0446 146 883	35 m (115 ft)	
0446 146 884	50 m (164 ft)	
0446 146 885	75 m (246 ft)	
0462 062 001	USB Memory stick 2 Gb	

WEAR PARTS

Feed rollers - SAW	
Part no.	D (mm)
0218 510 281	1.6
0218 510 282	2.0
0218 510 283	2.5
0218 510 286	4.0
0218 510 298	3.0-3.2

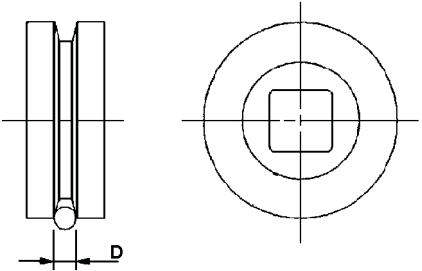



A WORLD OF PRODUCTS AND SOLUTIONS.



For contact information visit <http://esab.com>

ESAB AB, Lindholmsallén 9, Box 8004, 402 77 Gothenburg, Sweden, Phone +46 (0) 31 50 90 00

manuals.esab.com



CE

